

# APEC

112年第二季法人說明會  
2023 Q2 Investor Conference  
富鼎先進電子股份有限公司

2023/9/13



*Advanced Power Electronics Corp.*

Your best power solution partner



# 免責聲明 Safe Harbor Notice

本資料及相關討論可能包含對於未來展望的表述。該類表述是基於現況所得的預期，可能受各種已知或未知風險及不確定性因素影響，而造成實際結果與陳述內容發生顯著不符使用者應自行判斷與承擔投資風險。

This presentation and discussions contain forward looking statements. These statements are based on current expectations and are subject to known and unknown risks and uncertainties. Actual results may differ materially from those expressed or implied by these forward looking statements. Except as required by law, we undertake no obligation to update any forward looking statement, whether as a result of new information, future events, or otherwise.

# 公司簡介 About A-Power

- 設立於 1998 年  
Established in 1998
- 在臺首位結合DMOS與IGBT製程，並獲得ISO9001及ISO14001  
認證之公司  
First successfully integrated in DMOS and IGBT process in Taiwan  
with ISO9001 and ISO14001 certificate
- 提供MOSFET、IGBT和電源IC電源管理之解決方案  
Provide solutions for power requirements in MOSFET, IGBT, and  
Power IC
- 在臺灣證券交易所掛牌，證券代碼8261  
Listed on Taiwan Stock Exchange (TWSE) under ticker number  
8261
- 實收資本額為新台幣11.7億  
Capital: TWD 117M



# 全球行銷據點 Location & Sales Support

全球153位員工  
153 Employees Worldwide

China 中國  
Shanghai 上海

China 中國  
Wuxi 無錫

Japan 日本  
Tokyo 東京



Taiwan 台灣  
• Hsinchu 新竹  
• New Taipei 新北

中國 深圳  
China ShenZhen

- 總公司位於台灣
- Headquartered in Taiwan

- 區域辦公室: 中國/日本
- Regional offices: China / Japan

# 供應鏈分佈 Supply Chain

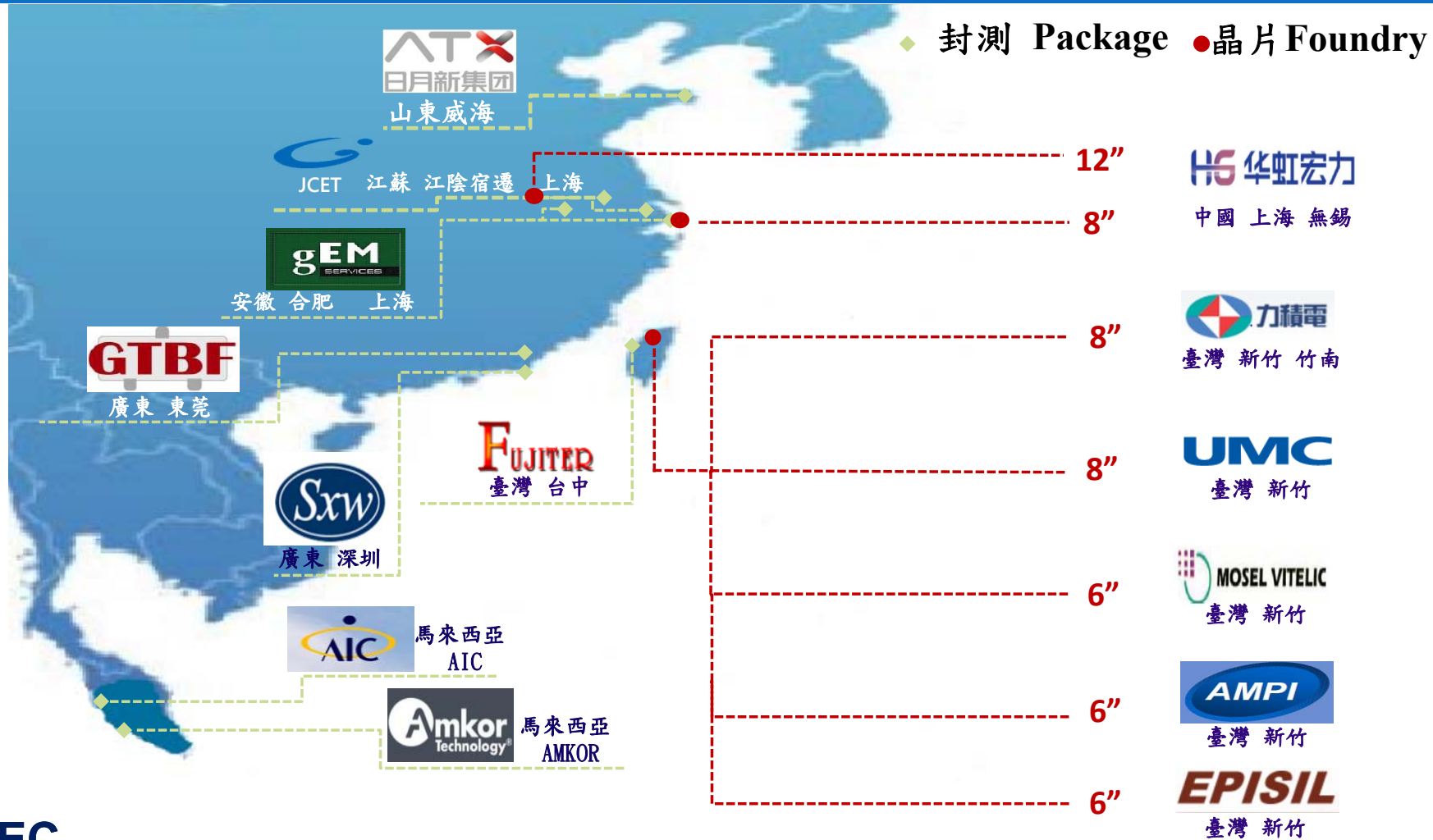

# 產品線 Product Overview

- Std. N MOSFETs (Planar)
- Std. -200V P MOSFETs (Planar)
- High ESD Protection Capability HV MOSFETs (Planar)
- Ultra Low Ron HV MOSFETs (Super Junction)
- Fast Recovering HV MOSFETs (Super Junction)
- SiC Schottky Barrier Diode
- SiC MOSFETs

高壓  
High Voltage  
MOSFET  
200~1200V  
Adaptor, Charger  
SPS, Server Power

低壓  
Low Voltage  
MOSFET  
≤40V  
M/B, NB, Server,  
Data Center, BLDC

- Std. N & P MOSFETs
- High ESD Protection Capability MOSFETs (ESD > 8KV)
- N MOSFETs with Schottky Diode
- Ultra Low Qgd N MOSFETs

- Std. N & P MOSFETs (Trench)
- High ESD Protection Capability MOSFETs (Trench)
- Ultra Low Qgd MOSFETs (SGT)
- Ultra Low Ron N MOSFETs (SGT)

E-Scooter, E-Tools,  
SRFET, BLDC  
中壓  
Mid. Voltage  
MOSFET  
60~150V

White Goods, EV Charger  
Sewing Machine  
PV Inverter  
絕緣閘雙載子  
IGBT  
400~1200V

- 400V Strobe Flash IGBT
- 600V FS IGBT
- 1200V FS IGBT
- 600V FS IGBT + FRD
- 1200V FS IGBT + FRD
- 600V/1200V FS RC-IGBT

# 產品應用 Product Application

## Personal Computer 個人電腦

主要應用: 桌上型電腦/Notebook/AIO/Gaming PC/POS



## BLDC Motor 直流無刷馬達

主要應用: 風扇/電動工具/無人機/掃地機/吸塵器/空調及家電

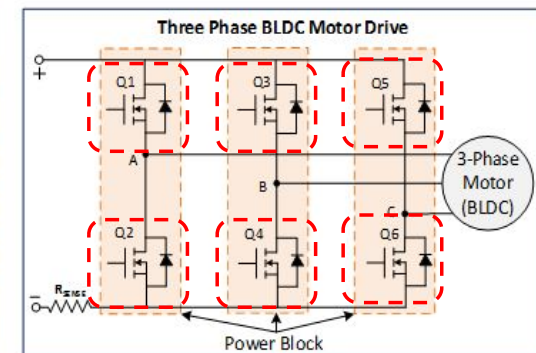
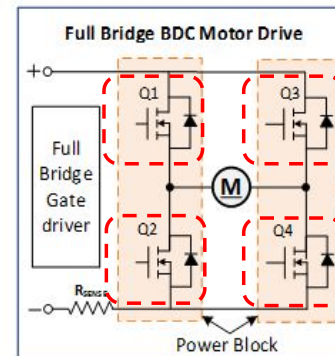
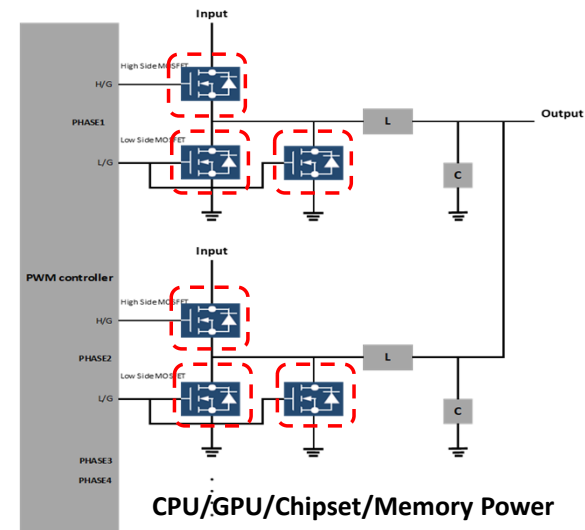

# 產品應用 Product Application

## SMPS 切換式電源供應器

主要應用: Charger / Adaptor / PC Power Supply / Gaming Power Supply / Server Power Supply

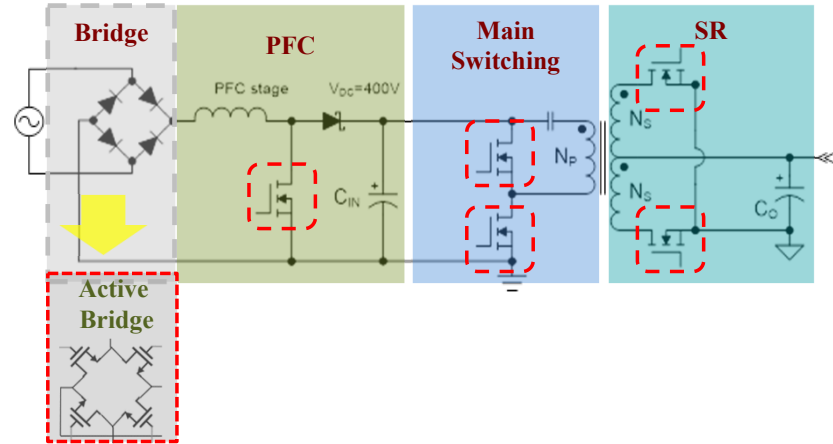

## Renewable Energy 新能源

主要應用: 再生能源儲能及供電系統

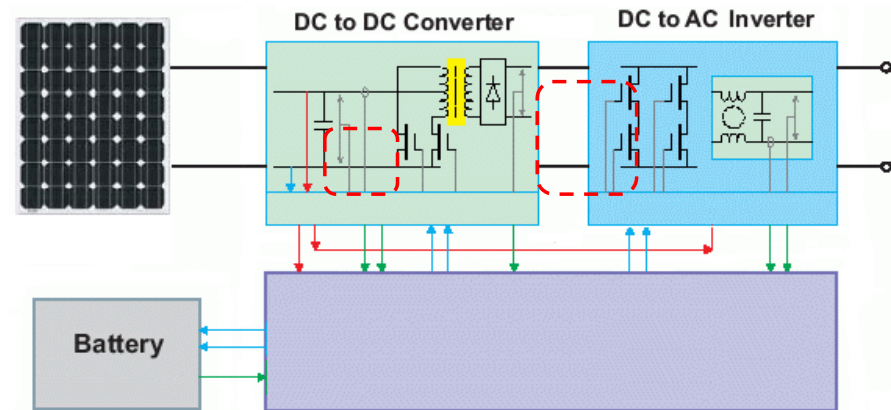
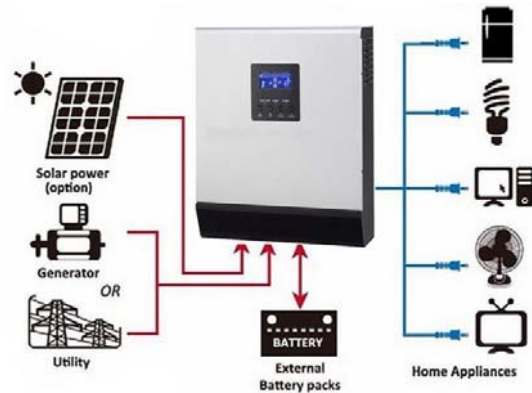

Converter/Inverter / BMS(電池管理系統)



# 產品封裝型態 Power Discrete Package List

## THP

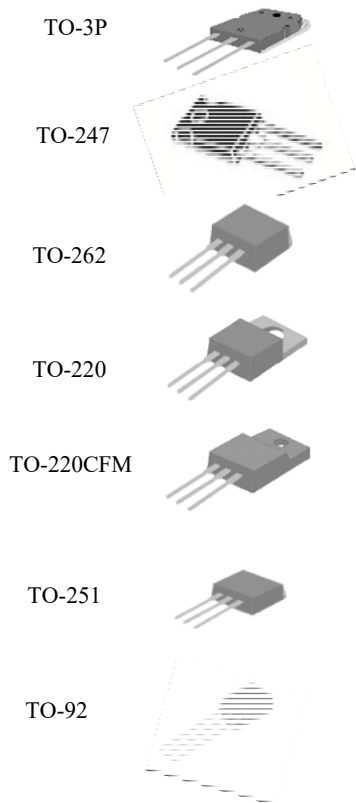

## SMD

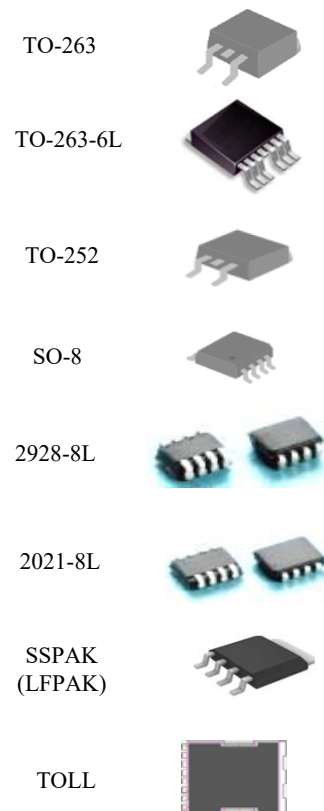

## SMD



## Leadless



*Note. Symbolic images only and not to scale*

# 2Q 2023 合併營收比重 Sales Breakdown

## By Product

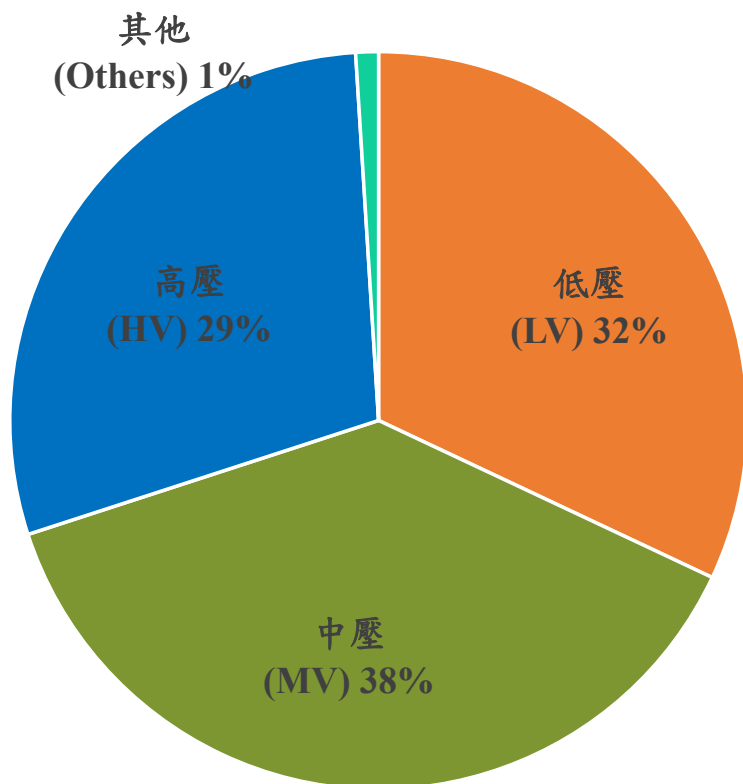

NT\$ 718,793K

QoQ +9.7%

YoY -38.2%

## By Region

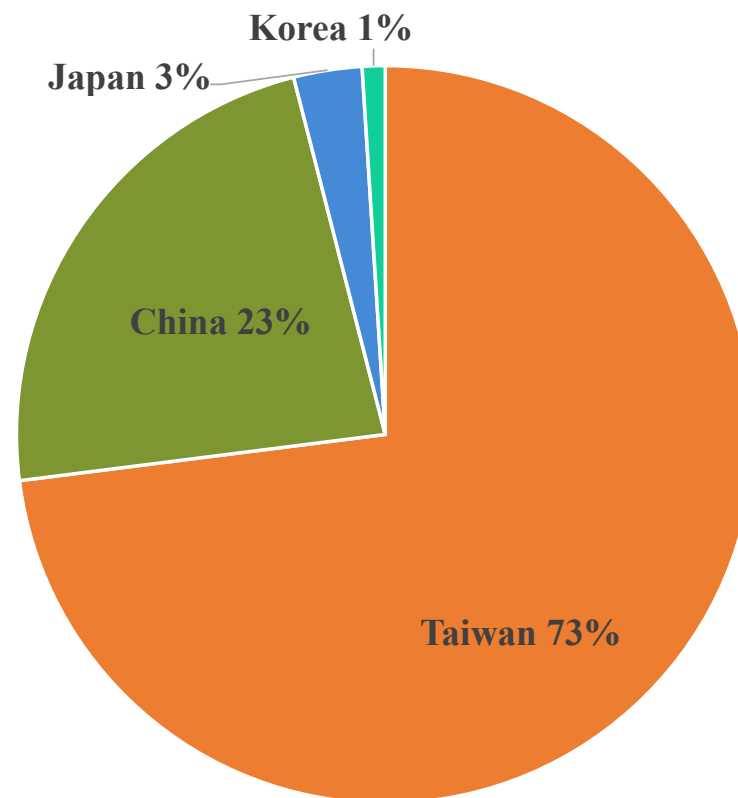

# 1H 2023 合併營收比重 Sales Breakdown

## By Product

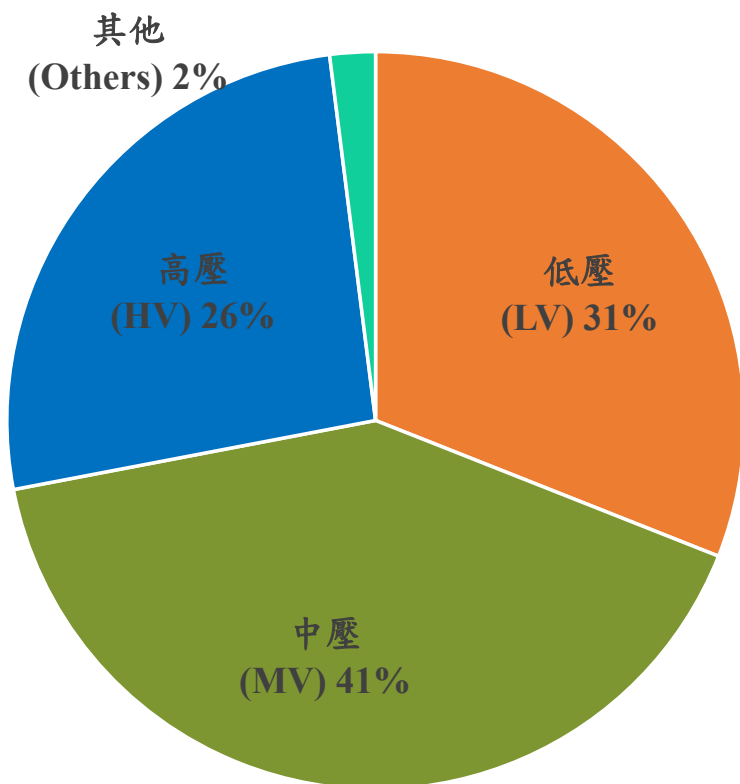

NT\$ 1,374,309K  
YoY -40.1%

## By Region

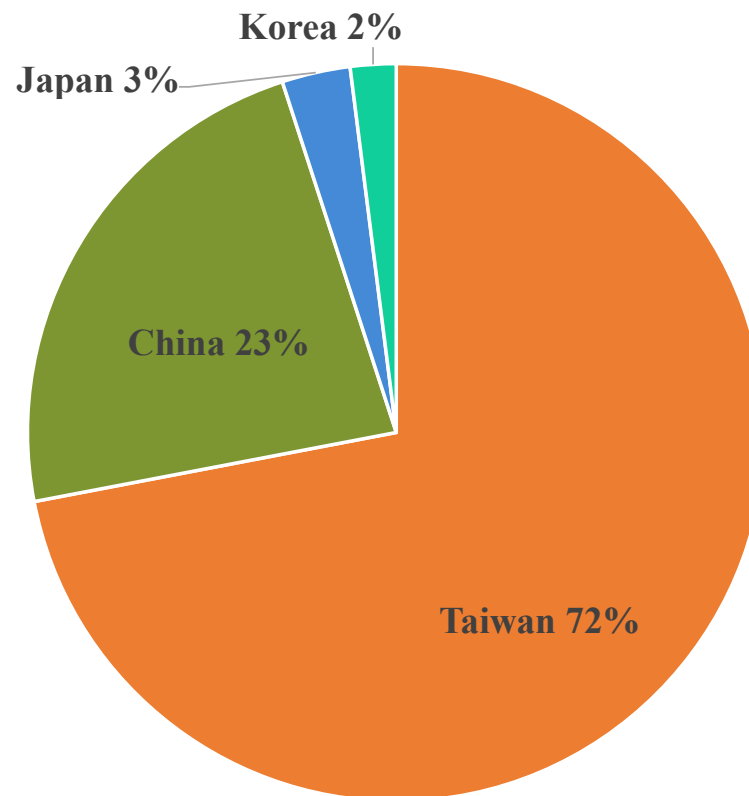

# 2Q2023 合併營收比重 Sales Breakdown

## By Channel

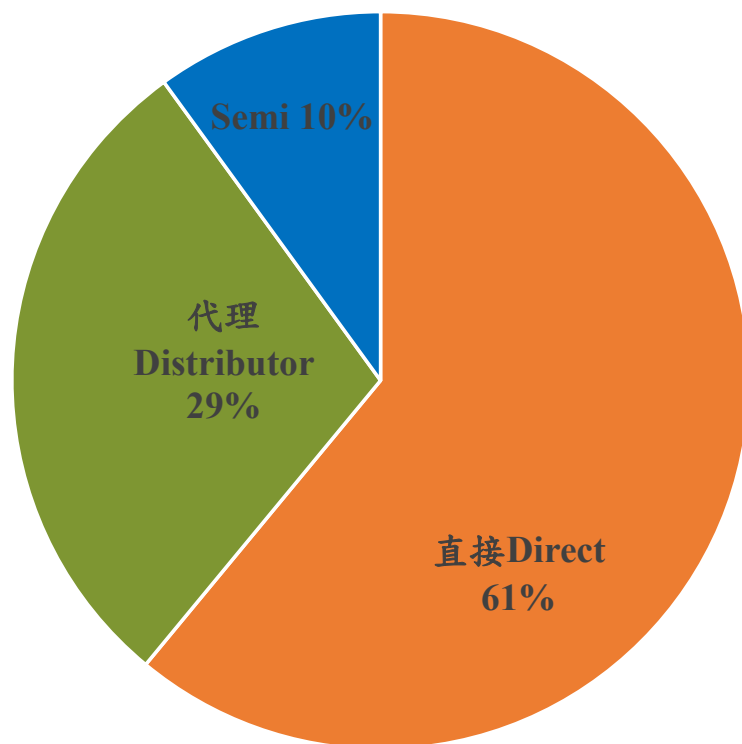

NT\$ 718,793K

QoQ +9.7%

YoY -38.2%

## By Segment

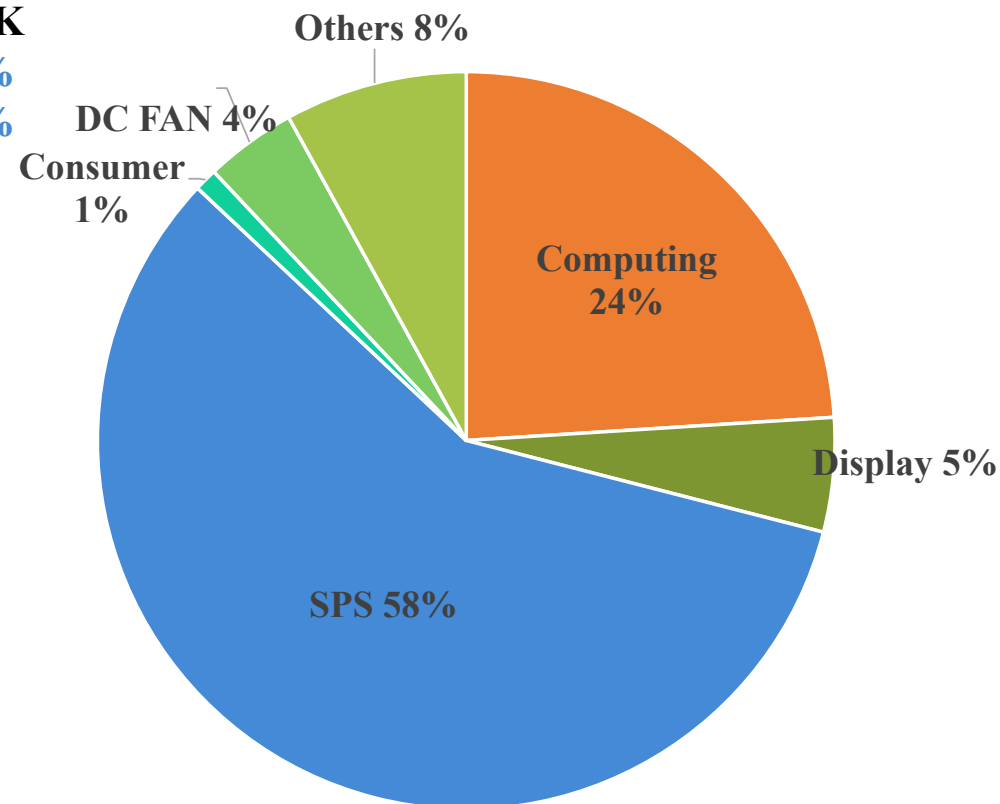

# 1H 2023 合併營收比重 Sales Breakdown

## By Channel

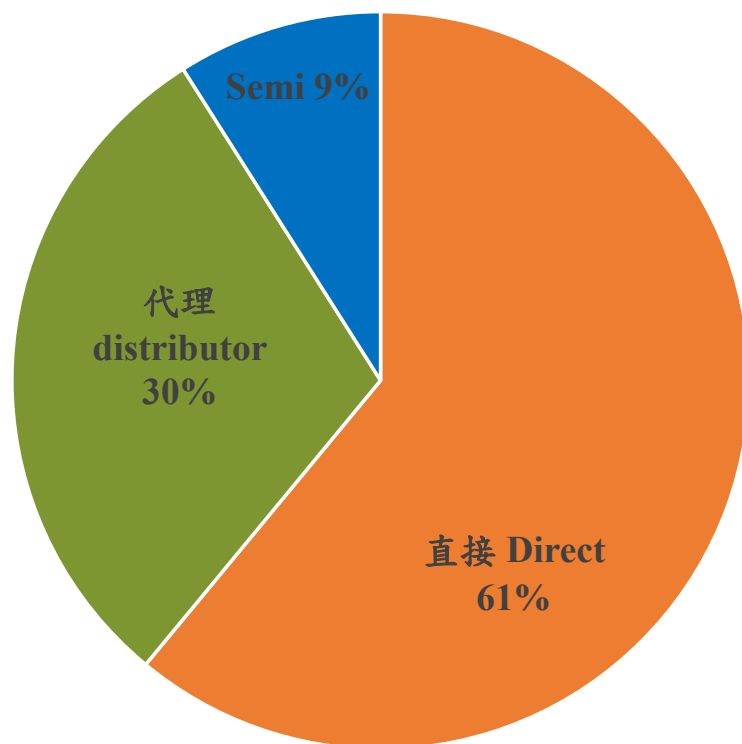

NT\$ 1,374,309K  
YoY -40.1%

## By Segment

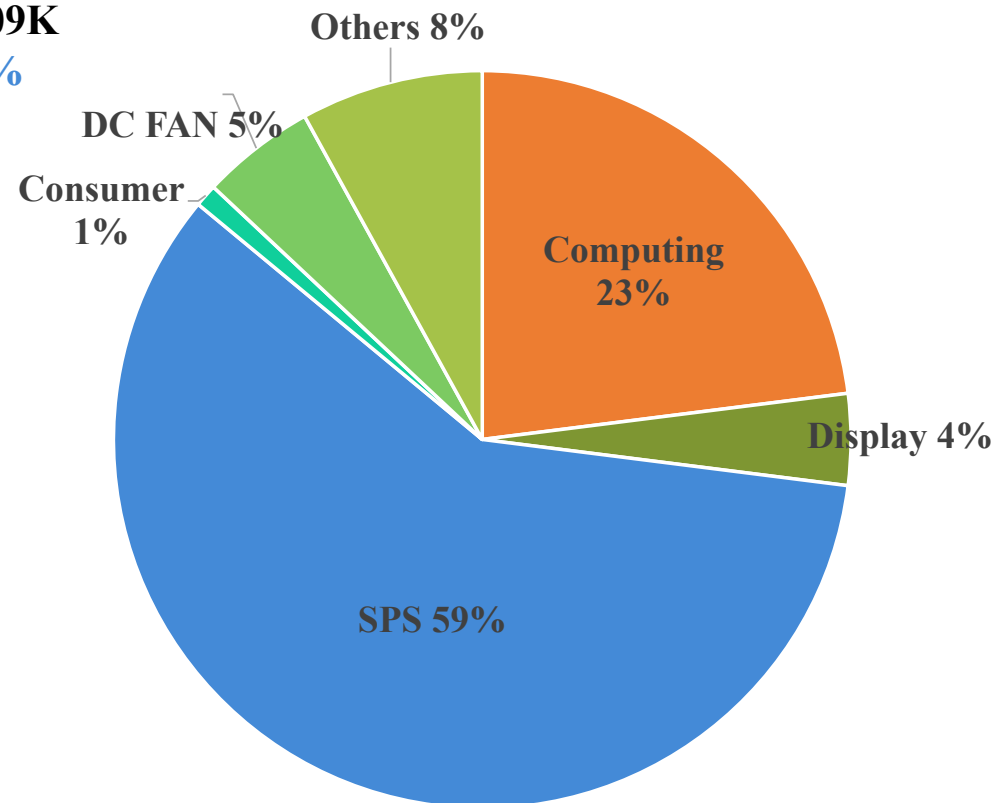

# 2Q2023 合併損益表 Income Statement

APEC Consolidation (reviewed)

Amount in NT\$ Thousand

	2Q23		1Q23		Q-Q	2Q22		Y-Y
	Amount	%	Amount	%	Change %	Amount	%	Change %
Net Sales	718,793	100.0	655,516	100.0	9.7	1,163,163	100.0	(38.2)
Cost of Sales	(559,807)	(77.9)	(482,864)	(73.7)	15.9	(724,419)	(62.3)	(22.7)
Gross Margin	158,986	22.1	172,652	26.3	(4.2) pts	438,744	37.7	(15.6) pts
Operating Expenses	(108,321)	(15.1)	(106,221)	(16.2)	1.1 pts	(132,103)	(11.4)	(3.7) pts
Operating Profit	50,665	7.0	66,431	10.1	(3.1) pts	306,641	26.4	(19.4) pts
Non-operating Items	47,425	6.6	5,215	0.8	5.8 pts	61,761	5.3	1.3 pts
Income Before Tax	98,090	13.6	71,646	10.9	36.9	368,402	31.7	(73.4)
Income Tax	(29,413)	(4.1)	(14,463)	(2.2)	(1.9) pts	(80,631)	(6.9)	2.8 pts
Net Income	68,677	9.6	57,183	8.7	20.1	287,771	24.7	(76.1)
Noncontrolling Interests	459	0.1	278	0.0	65.1	621	0.1	(26.1)
Net Income (attributable to the parent)	69,136	9.6	57,461	8.8	20.3	288,392	24.8	(76.0)
EPS (NT\$ Dollar)	0.59		0.49		20.4	3.09		(80.9)
EBITDA	106,763	14.9	79,869	12.2	33.7	375,233	32.3	(71.5)

- Q-Q/Y-Y Change of Net Sales, Cost of Sales, Income Before Tax, Net Income, EPS is in %, the rest of Changes is in percentage point.

- The financial data is based on T-IFRS

# 1H 2023 合併損益表Income Statement

APEC Consolidation (reviewed)

Amount in NT\$ Thousand

	1H2023		1H2022		Y-Y
	Amount	%	Amount	%	Change %
Net Sales	1,374,309	100.0	2,294,871	100.0	(40.1)
Cost of Sales	(1,042,671)	(75.9)	(1,423,922)	(62.0)	(26.8)
Gross Margin	331,638	24.1	870,949	38.0	(13.9) pts
Operating Expenses	(214,542)	(15.6)	(259,406)	(11.3)	(4.3) pts
Operating Profit	117,096	8.5	611,543	26.6	(18.1) pts
Non-operating Items	52,640	3.8	116,325	5.1	(1.3) pts
Income Before Tax	169,736	12.4	727,868	31.7	(76.7)
Income Tax	(43,876)	(3.2)	(153,862)	(6.7)	3.5 pts
Net Income	125,860	9.2	574,006	25.0	(78.1)
Net Income (attributable to the parent)	126,597	9.2	575,431	25.1	(78.0)
EPS (NT\$ Dollar)	1.08		6.59		(83.6)
EBITDA	186,632	13.6	741,501	32.3	(74.8)

- Q-Q/Y-Y Change of Net Sales, Cost of Sales, Income Before Tax, Net Income, EPS is in %, the rest of Changes is in percentage point.  
 - The financial data is based on T-IFRS

# 合併資產負債表摘要 Balance Sheet Summary

APEC Consolidation (reviewed)

Amount in NT\$ Thousand

	As of June 30 2023	As of Mar 31 2023	Q-Q Change %	As of June 30 2022	Y-Y Change %
Cash and cash equivalents	3,310,861	3,407,585	(2.8)	3,376,649	(1.9)
Receivables	829,010	688,432	20.4	1,097,323	(24.5)
Inventory	810,481	870,518	(6.9)	772,477	4.9
<b>Total Assets</b>	<b>6,263,942</b>	<b>6,252,085</b>	<b>0.2</b>	<b>6,474,958</b>	<b>(3.3)</b>
Payables	355,792	339,084	4.9	731,175	(51.3)
<b>Total Liabilities</b>	<b>1,188,168</b>	<b>671,010</b>	<b>77.1</b>	<b>1,306,320</b>	<b>(9.0)</b>
<b>Total Equity</b>	<b>5,075,774</b>	<b>5,581,075</b>	<b>(9.1)</b>	<b>5,168,638</b>	<b>(1.8)</b>
<b>Total Liabilities &amp; Equity</b>	<b>6,263,942</b>	<b>6,252,085</b>	<b>0.2</b>	<b>6,474,958</b>	<b>(3.3)</b>
ROE (Quarterly)	1.3%	1.0%	0.3 pts	7.8%	(6.5) pts
ROE (Annualized)	4.8%	4.1%	0.7 pts	31.1%	(26.3) pts

- The financial data is based on T-IFRS





# THANK YOU

---

Your Best **Power** Solution Partner.